



The University of Sydney
AUSTRALIA

School of Electrical and Information Engineering

Advanced Communication Networks

Chapter 3

ISDN Interfaces and Functions

Based on chapter 6 of Stallings ISDN-4e book

Abbas Jamalipour

3.1 Transmission Structure

- Digital pipe between central office and ISDN subscriber carry a number of communication channels, varies from user to user.
- The transmission structure of access links includes channels of:
 - **B channel:** 64 kbps
 - **D channel:** 16 or 64 kbps
 - **H channel:** 384 (H_0), 1536 (H_{11}), or 1920 (H_{12}) kbps
- **B channel**
 - a user channel, carrying digital data, PCM-encoded digital voice, or a mixture of lower-rate traffic at a fraction of 64 kbps
 - the elemental unit of circuit switching is the B channel
 - Three kinds of connections which can be set up over a B channel are
 - **Circuit-switched:** equivalent to switched digital service, call establishment does not take place over the B channel but using CCS
 - **Packet-switched:** user is connected to PS node, data exchanged via X.25
 - **Semipermanent:** equivalent to a leased line, not requiring call establishment protocol, connection to another user by prior arrangement
- **D channel**
 - carries CCS information to control circuit-switched calls
 - may be used for PS or low speed telemetry when no signaling infor.

B Channel (64 kbps)	D Channel (16 kbps)
Digital voice	Signaling
64 kbps PCM	Basic
Low bit rate (32 kbps)	Enhanced
High-speed data	Low-speed data
Circuit switched	Videotex
Packet switched	Teletex
Other	Terminal
Facsimile	Telemetry
Slow-scan video	Emergency services
	Energy management

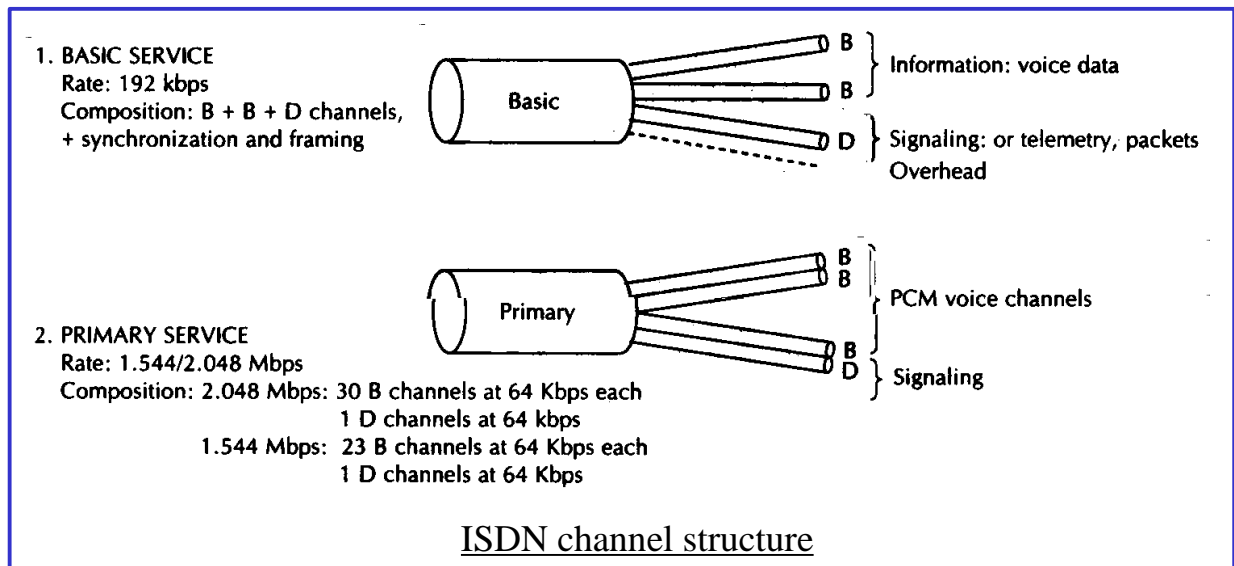

- **H channel**

- provides user information transmission at higher data rates
- use the channel as a high-speed trunk or subdivide it based on TDM
- examples: fast fax, video, high-speed data, high quality audio

Basic and Primary Channel Structures

- **Basic Channel Structure (Basic Access)**

- consists of two full-duplex 64 B-chs and a full-duplex 16 D-ch.
- with overheads such as framing and sync. Total bit rate is 192 kbps
- to meet the needs of residential subscribers and small offices
- access through a single multifunction terminal or separate terminals
- simultaneous use of voice and data applications (PS access)

- **Primary Channel Structure (Primary Access)**

- different data rates in different countries
- for users with greater capacity needs such as offices w/ LAN, PBX
- supporting H channels
 - primary rate interface H_0 channel structures ($3H_0 + D$, $4H_0$, and $5H_0 + D$)
 - primary rate interface H_1 channel structures (one H_{11} and one $H_{12} + D$)
 - primary rate interface structures for mixed B and H_0 channels
zero or one D+ combination of B and H_0 channels
(e.g., $3H_0 + 5B + D$ or $3H_0 + 6B$ for 1.544-Mbps interface)

3.2 User-Network Interface Configurations

- ITU-T approach for actual user's physical configuration
 - **functional grouping:** certain arrangements of physical equipment
 - **reference points:** conceptual points of separation of group function
- using a similar analogy with OSI model, i.e., layering
- equipment has only to conform to relevant interface standards
- *NT1:*
 - includes functions similar to OSI layer 1
 - may be controlled by the ISDN provider (a boundary to network)
 - performs line maintenance functions
 - supports multiple channels (e.g., 2B+D) using TDM
 - might support multiple devices in a multidrop arrangement
- *NT2:*
 - an intelligent device that may include up to OSI layer 3

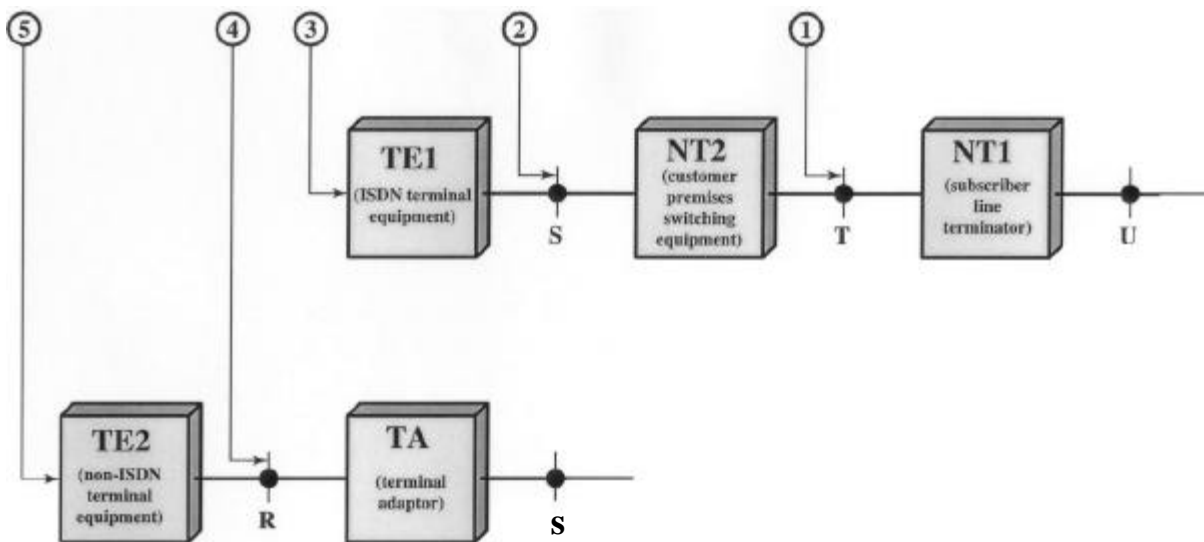

TE: terminal equipment

NT: network termination

TA: terminal adaptor

R, S, T, U: reference interface points

ISDN reference points and functional groupings

Reference points and functional grouping

- examples are digital PBX, a terminal controller, a LAN
- example of a switching function:
construction of a private network using semipermanent circuits among a number of sites
- Terminal equipment is the subscriber equip. using ISDN
- *TE1*:
 - devices that support the standard ISDN interface
 - examples: digital telephone, integrated voice/data terminals, dig. fax
- *TE2*
 - the existing non-ISDN equipment
 - examples: physical interface RS-232, host computer with X.25
 - requires a terminal adaptor (TA)
- *Reference point T*
 - a minimal ISDN network termination at customer's premises
 - separates network's provider equipment from the user's one
- *Reference point S*
 - the interface of individual ISDN terminals
 - separates user terminal from network communications functions

Functions of ISDN functional grouping

NT1	NT2	TE
Line transmission termination	Layers 2 and 3 protocol handling	Protocol handling
Line maintenance and performance monitoring	Layers 2 and 3 multiplexing	Maintenance functions
Timing	Switching	Interface functions
Power transfer	Concentration	Connection functions to other equipment
Layer 1 multiplexing	Maintenance functions	
Interface termination, including multidrop termination employing layer 1 contention resolution	Interface termination and other layer 1 functions	

Service support and Access configurations

- *Reference point R*
 - provides a non-ISDN interface between user equipment that is not ISDN compatible and adaptor equipment
 - comply with X or V series ITU-T recommendation
- *Reference point U*
 - describes full-duplex data signal on the subscriber line

Service Support

- Bearer services supported by ISDN are accessed at points 1 and/or 2 (RFs *T* and *S*).
- Other standardized services such as X and V series interfaces are accessed at access point 4 (RF *R*).
- Access points 3 and 5 provide access to teleservices.

Access Configurations

- Based on definitions of functional grouping and reference points, several possible configurations for ISDN user-network interface have been proposed by ITU-T.
 - The most straightforward configuration is that one or more pieces of equipment correspond to each functional grouping:

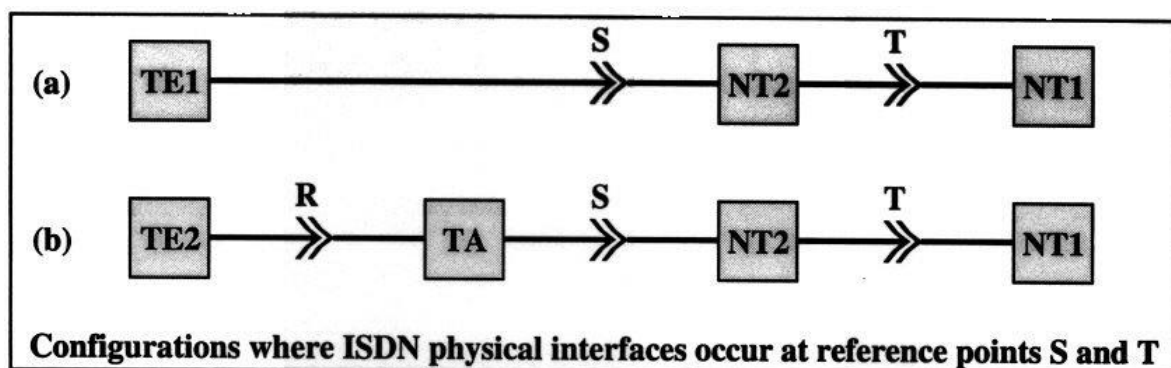

- In second case, the line termination function is combined with other ISDN interface functions.
- In the third case, NT2 and TE functions are combined.
- Final case: An ISDN device can connect directly to the subscriber loop terminator or into a LAN using same interface.

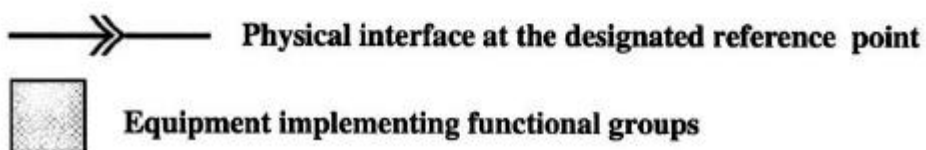
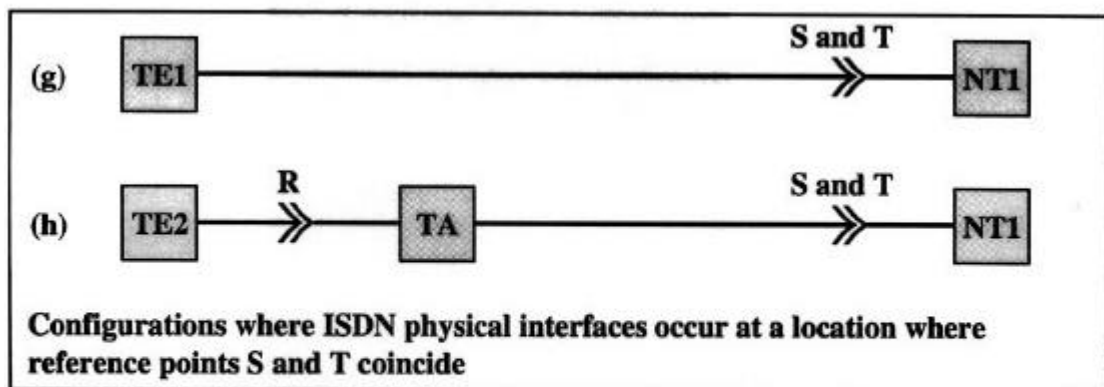
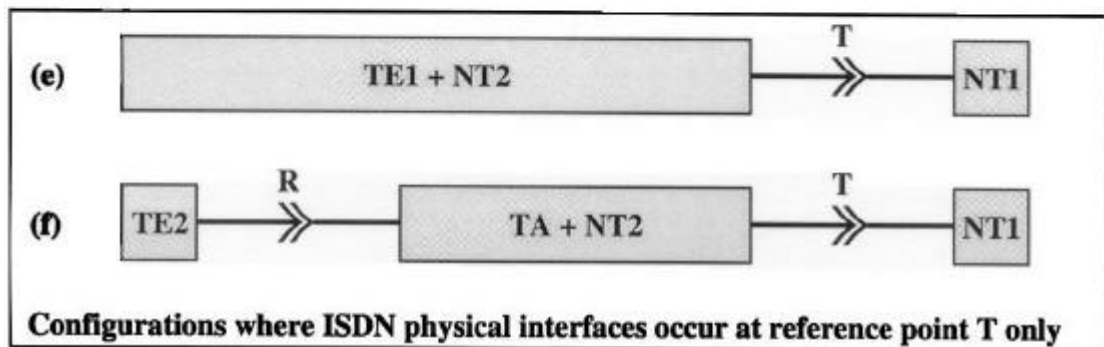
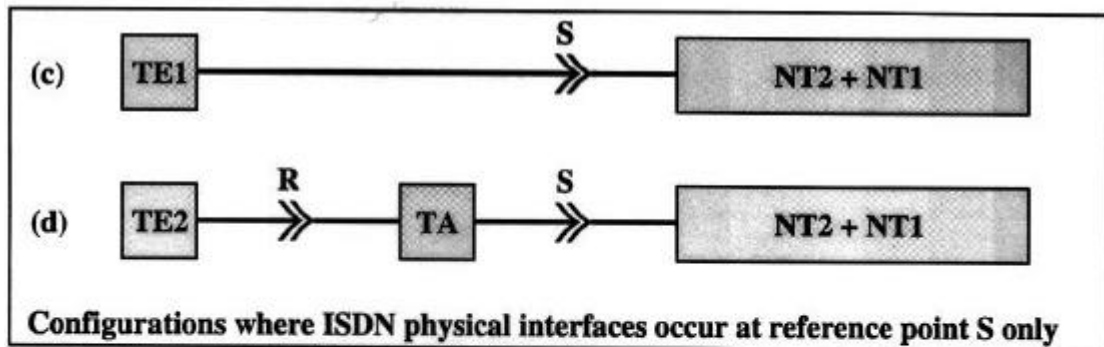

Examples of implementation of NT1 and NT2 functions

A given ISDN function can be implemented using various technologies and that different ISDN functions can be combined in a single device.

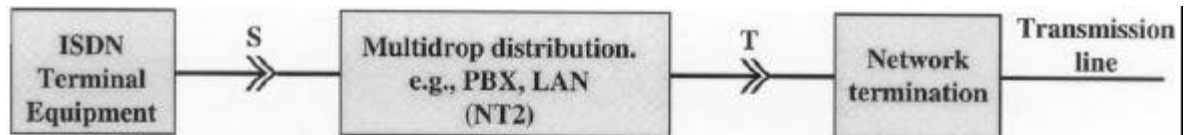

(a) An implementation where ISDN physical interfaces occur at reference points S and T (see Figure 6.3a)

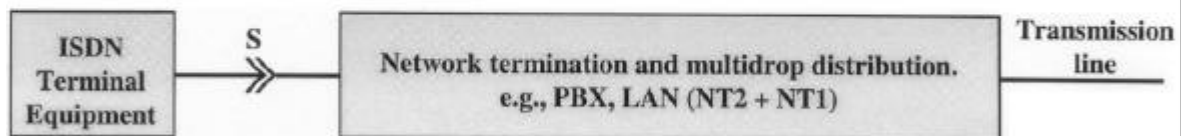

(b) An implementation where an ISDN physical interface occurs at reference point S but not T (see Figure 6.3c)

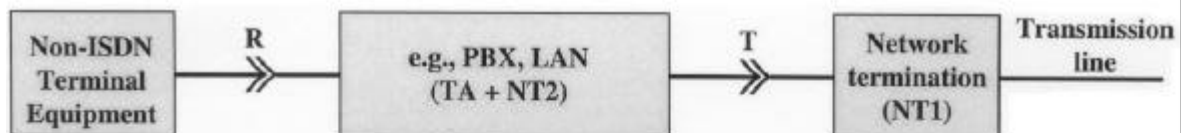

(c) An implementation where an ISDN physical interface occurs at reference point T but not S (see Figure 6.3f)

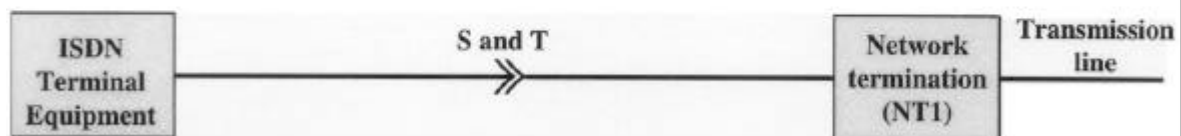

(d) An implementation where a single ISDN physical interface occurs at a location where reference points S and T coincide (see Figure 6.3g)

Possible configuration for ISDN user-network interfaces

Additional ITU-T configurations when the subscriber has more than one device at a particular interface point.

- (a) and (b): terminals can communicate with network not to each other
- (c) and (d): correspond to PBX and LAN
- (e): multiple NT1 equipment
- (f): NT1 provides a layer 1 multiplexing of multiple connections
- (g) and (h): either S or T, not both, need not correspond to a physical interface in a particular configuration

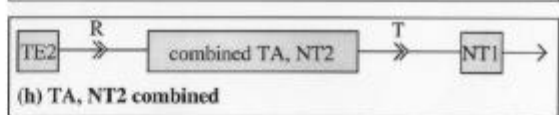
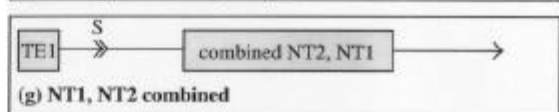
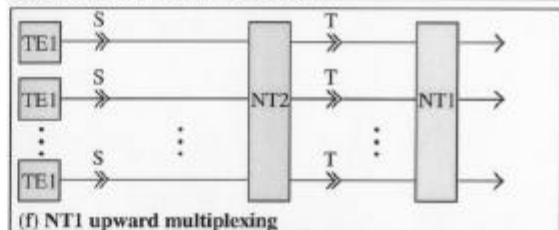
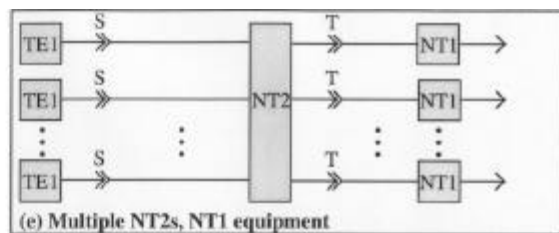
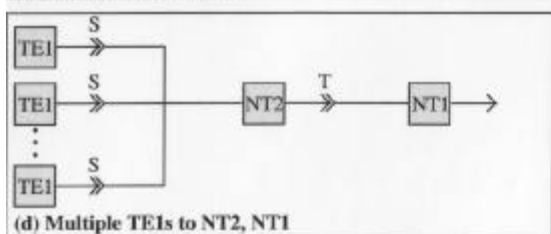
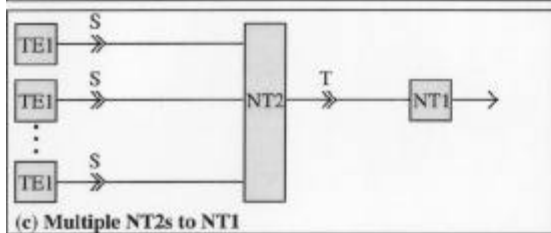
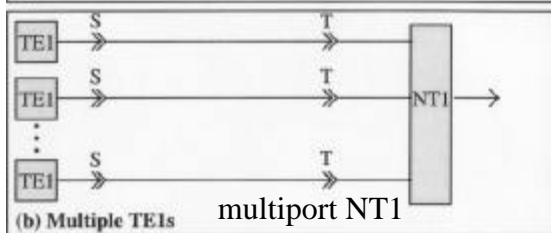
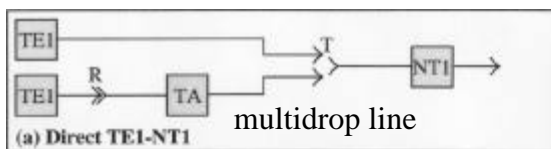

3.3 ISDN Protocol Architecture

- It is good if we can fit ISDN protocols into the OSI model, however, the simple 7-layer stack does not capture the relationship between a control signaling protocol on the D channel being used to set up, maintain, and terminate a connection on the B or H channel.
- Thus, ITU-T defined I.320, a two layered stacks of protocols.
 - **User protocol block:** transparent transfer of user information (X.25)
 - **Control protocol block:** supporting ISDN signaling
 - controlling a network connection
 - controlling multimedia calls
 - controlling the use of an already established connection
 - providing supplementary services
- The ISDN protocol reference model includes a plan management function that cuts across all the protocol layers.
 - that enable a network management system to control the parameters and operation of remote systems.

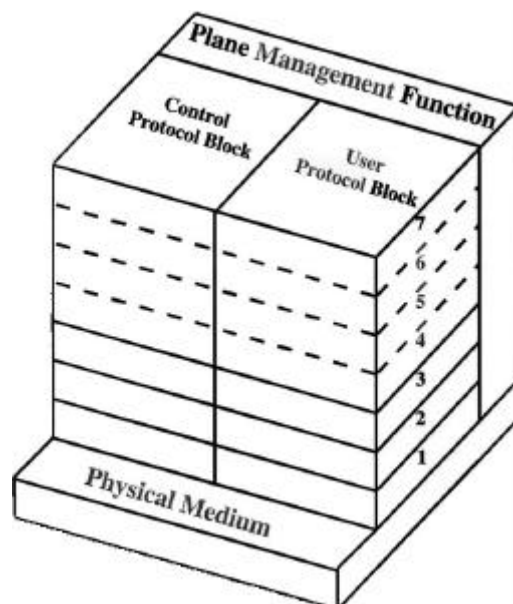

Global view of protocol architecture

ISDN protocols at the user-network interface

- Control signaling is a D channel function but user data may also be transferred across the D channel.
- ISDN is essentially unconcerned with user layers 4-7.
- LAPD (link access protocol, D channel) is based on HDLC but modified for ISDN.
- Applications supported: control signaling, PS, and telemetry

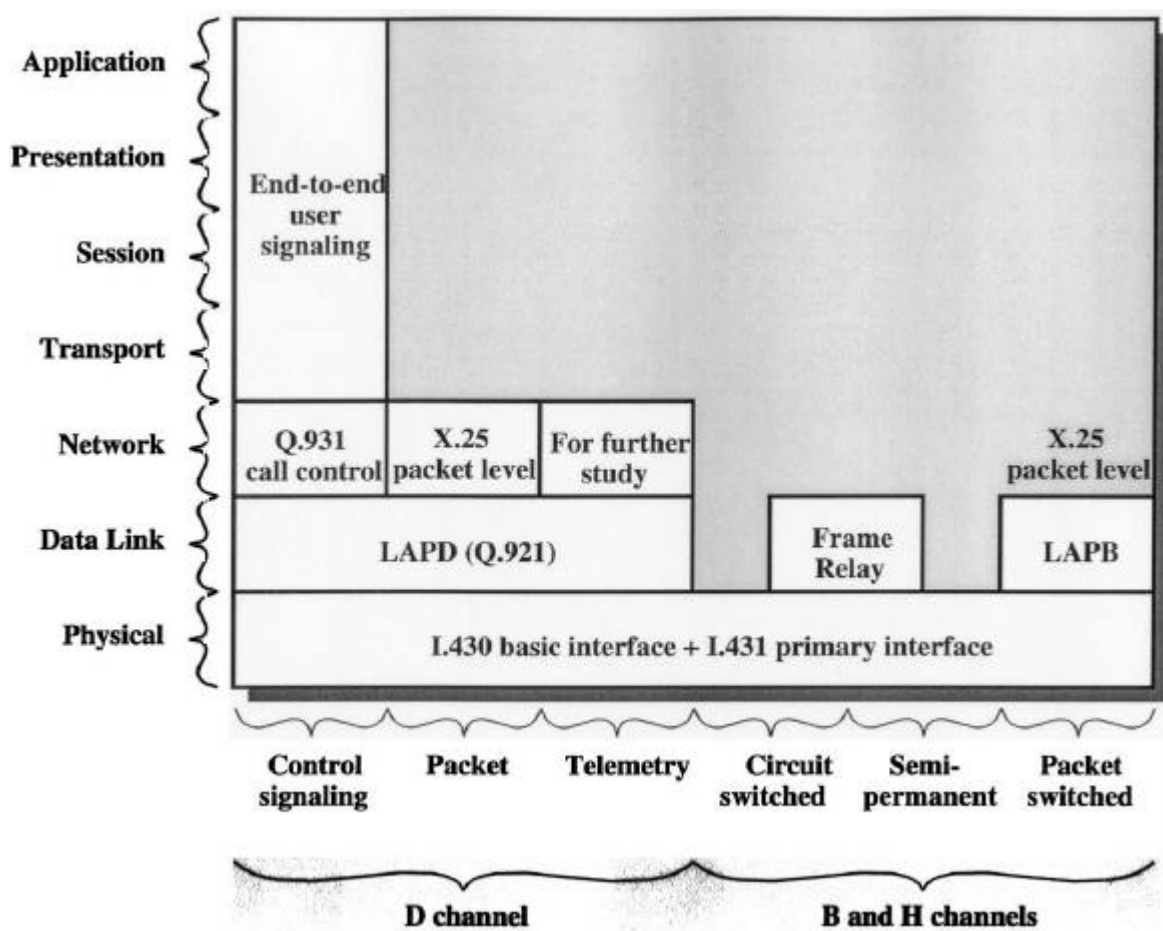

3.4 ISDN Connections

- End-to-end communication services in narrowband ISDN:
 - circuit-switched calls over a B or H channel
 - semipermanent connections over a B or H channel
 - packet-switched calls over a B or H channel
 - packet-switched calls over a D channel
 - frame relay calls over a B or H channel
 - frame relay calls over a D channel

Circuit switching

- configuration and protocols in both B and D channels
 - B channel: for transparent exchange of user data
 - D channel: for exchange of control information (user ↔ network)

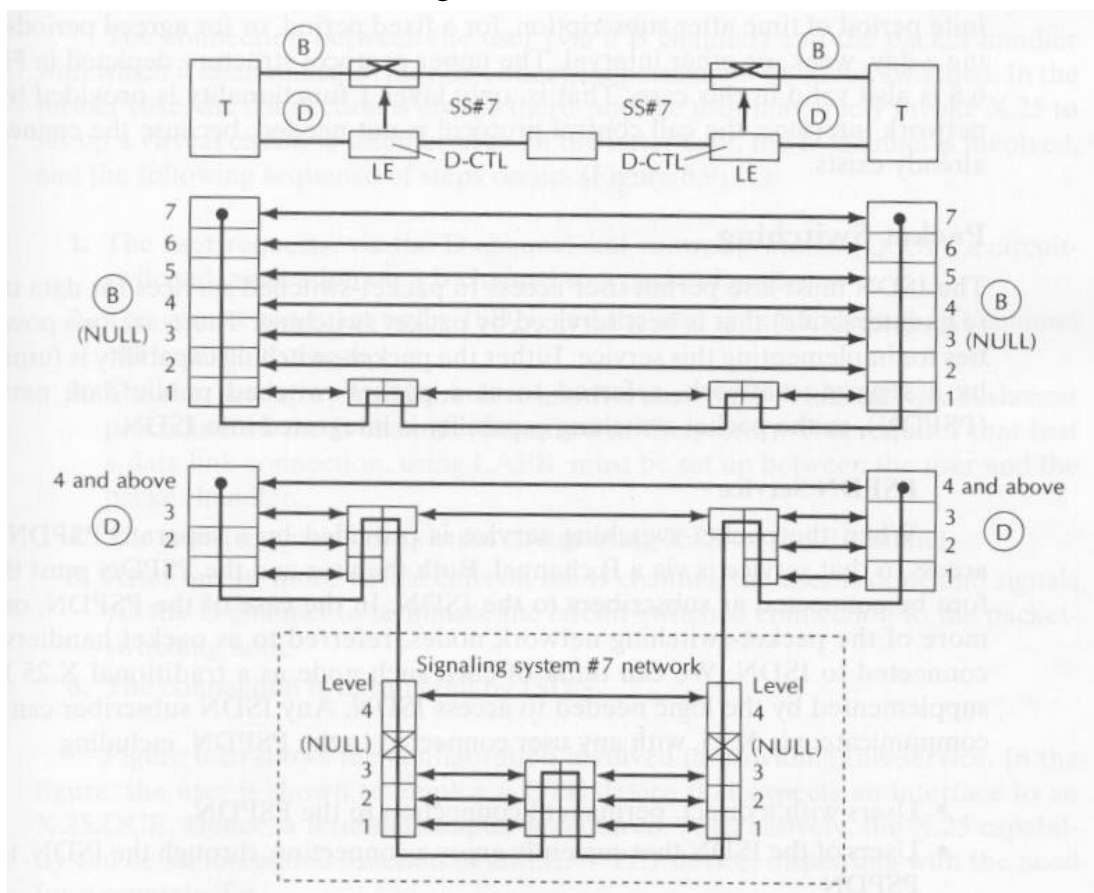

Network configuration and protocols for circuit switching

Semipermanent connections

- provide connection between agreed points for a period of time
- only layer 1 functionality is provided by network interface

Packet switching

- implementation of packet switched services by:
 - a separate network: packet-switched public data network (PSPDN)
 - the packet-switching capability integrated into ISDN

PSPDN Service

- access via a B channel: user and PSPDN are ISDN subscribers
- one or more PS nodes connected to ISDN such as X.25 DCE
- connection between user (via B ch.) and *packet handler* either semipermanent or circuit-switched (D ch. is involved).

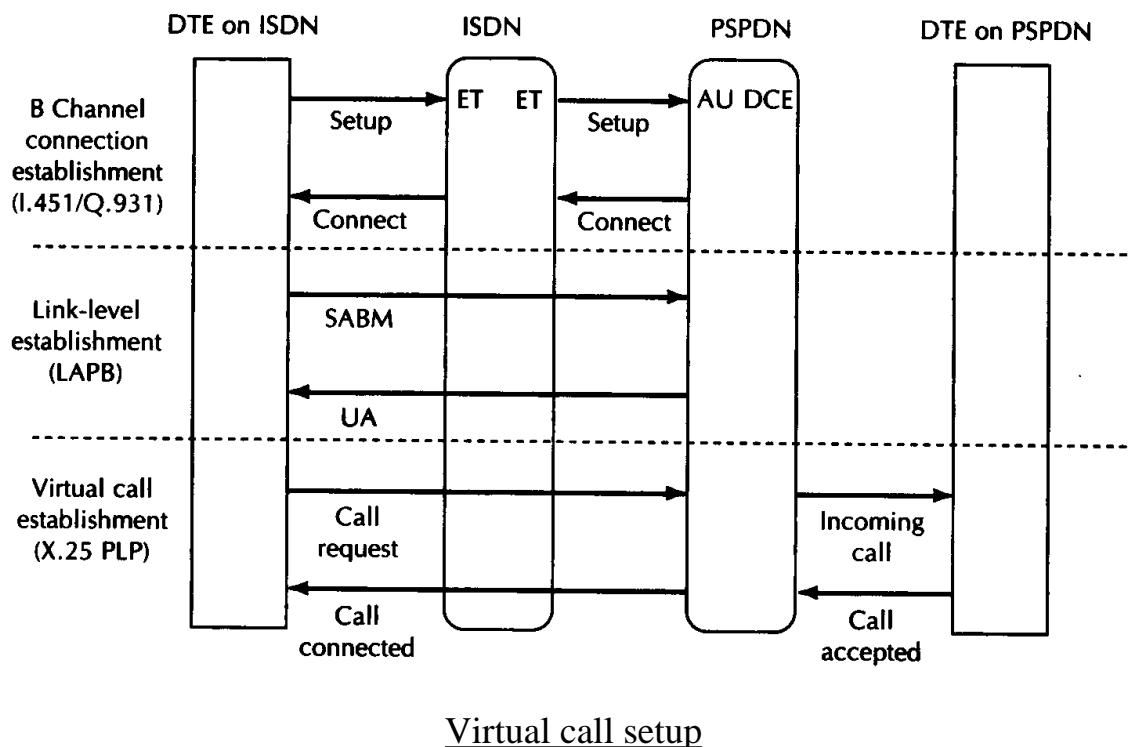

- The user requests a circuit-switched connection on a B channel via D channel to a packet handler (Q.931)
- The connection is set up by ISDN, user is notified via D channel
- The user is set up a VC to another user via X.25 call establishment procedure on B channel
- The user terminates the VC using X.25 on B channel
- After one or more virtual calls on B channel, the user signals via D channel to terminate the circuit-switched connection to P node
- The connection is terminated by ISDN

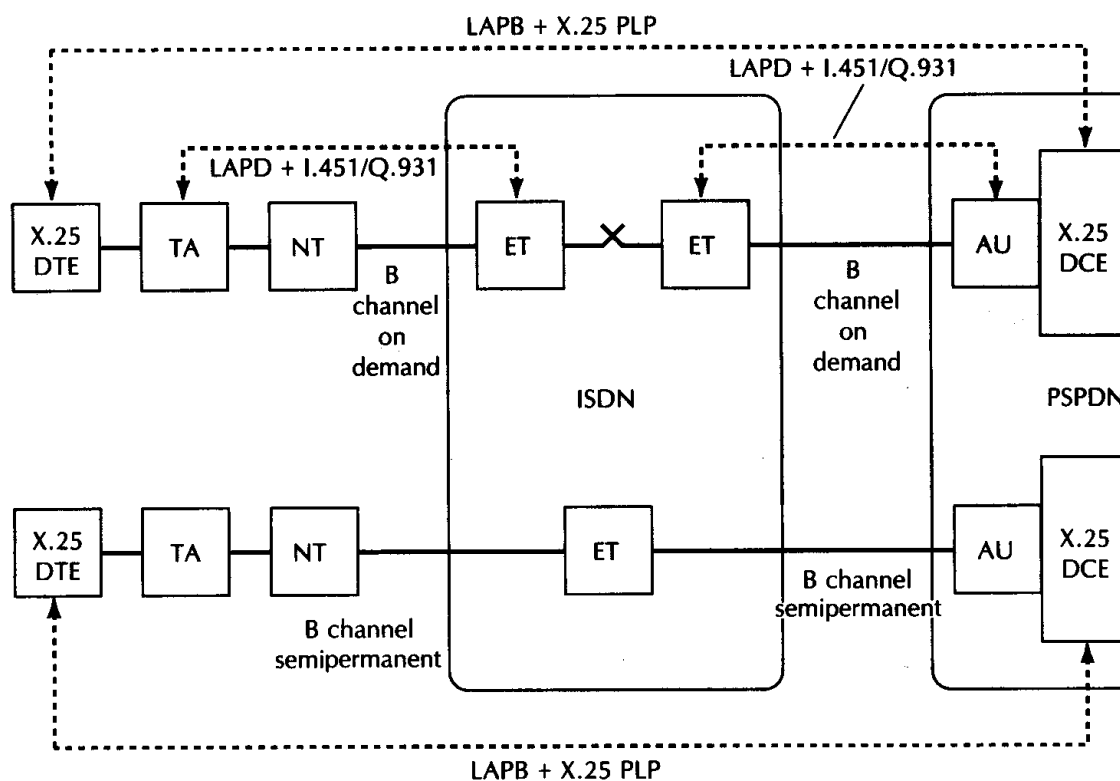

AU = ISDN access unit
 TA = Terminal adapter
 NT = Network termination 2 and/or 1
 ET = Exchange termination
 PLP = Packet-level procedure
 PSPDN = Packet-switched public data network

The user employs a DTE device that expects an X.25 DCE interface; a TA is required. If X.25 capability integrated in ISDN TE1 device, TA is not required.

Access to PSPDN for packet-mode service

ISDN Service

- The packet-handling function is provided within ISDN
 - by separate equipment
 - as part of the exchange equipment
- The user may connect to a packet handler by a B or D channel.
- On a B channel, the connection to the packet handler may be either switched or semipermanent.
- In this case, the connection is to an internal element of ISDN that is a packet handler.
- For D channel access, ISDN provides a semipermanent connection to a packet-switching node within the ISDN.
- Layer 3 protocol is carried by LAPD frames.
- Link layer addressing schemes is used to distinguish between X.25 packet traffic and ISDN control traffic on D channel.

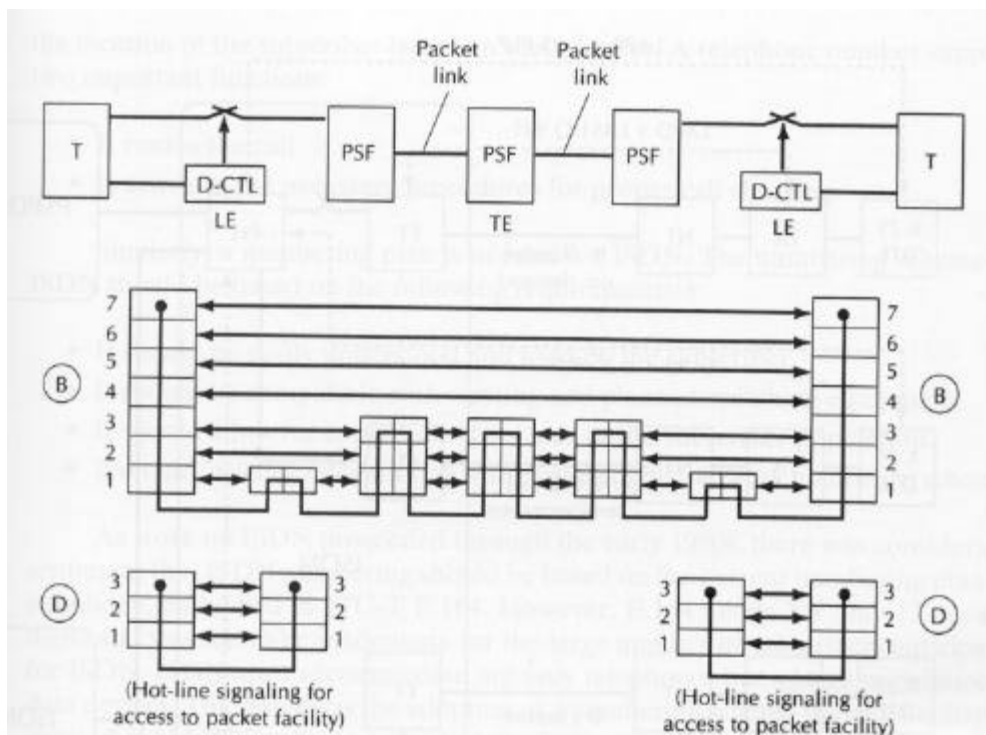

Network configuration and protocols for packet switching using B channel with circuit-switched access

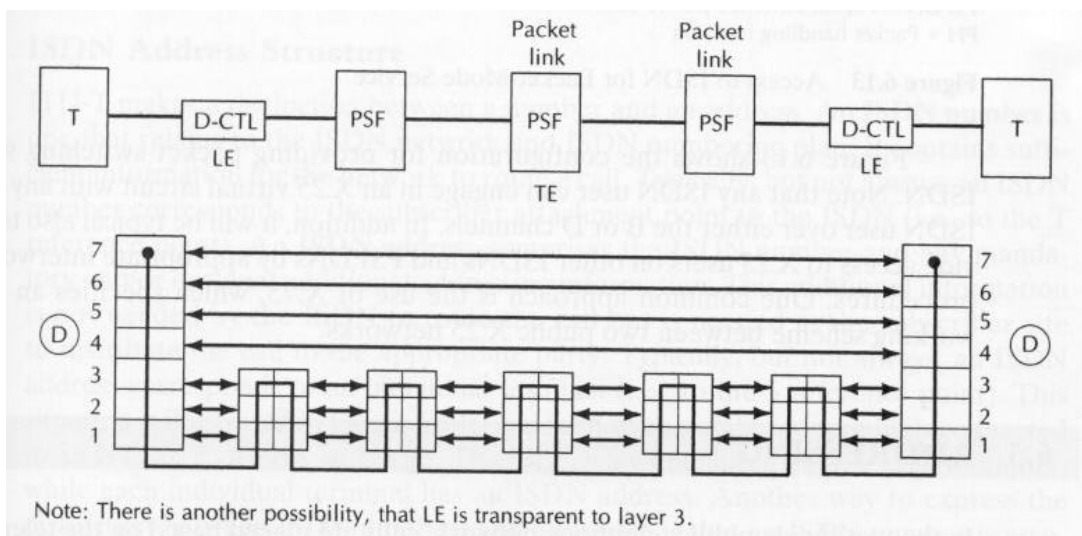

Network configuration and protocols for packet switching

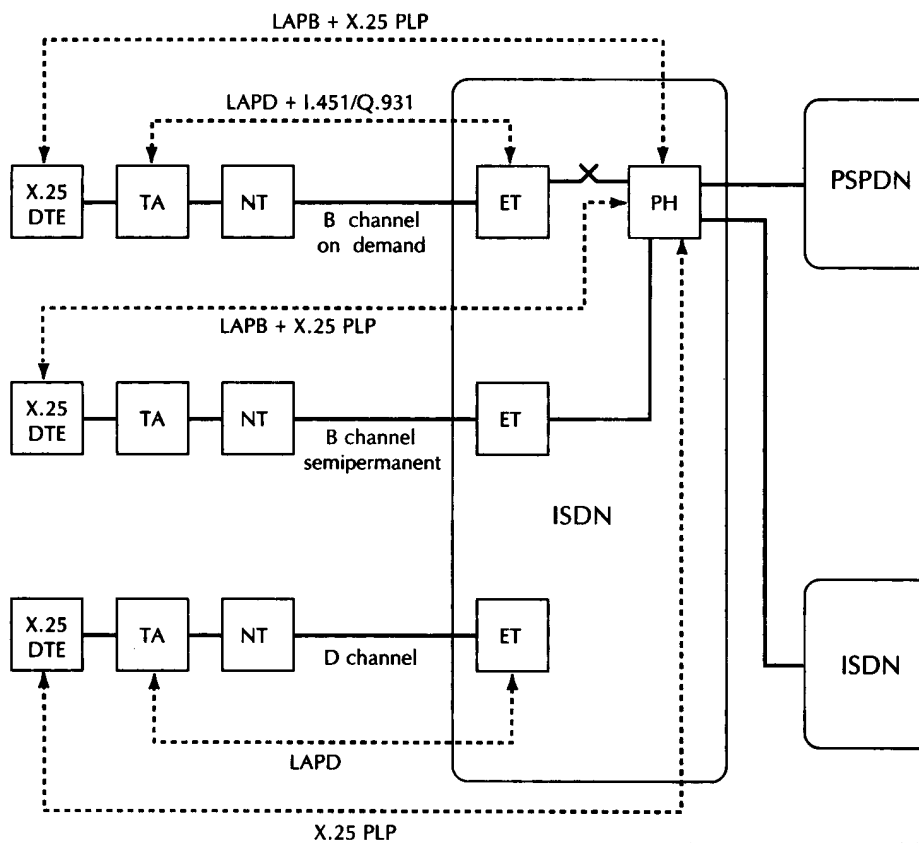

- Any ISDN user can have an X.25 VC with another user over B or D channels.
- May have access to X.25 users on other ISDNs and PSPDNs (e.g., X.75: internetworking scheme between two public X.25 networks)

Access to ISDN for packet-mode service

3.5 Addressing

- Telephone numbers support two important functions:
 - call routing
 - activating the necessary procedures for call charging
- ISDN numbering requirements
 - easily understandable and usable by the subscribers
 - compatible with existing and planned switching equipment
 - expandable to larger number of subscriber population
 - facilitates internetworking with existing public network numbering
- ITU-T E.164 with 12 decimal digits is inadequate for ISDN
- ISDN numbering plan:
 - it is an enhancement of E.164
 - it is independent of the nature of service or the performance
 - it is a sequence of decimal digits (not alphanumeric)
 - internetworking between ISDNs requires the use of ISDN number
- ISDN address structure
 - The address appearing in call setup messages in CCS protocols

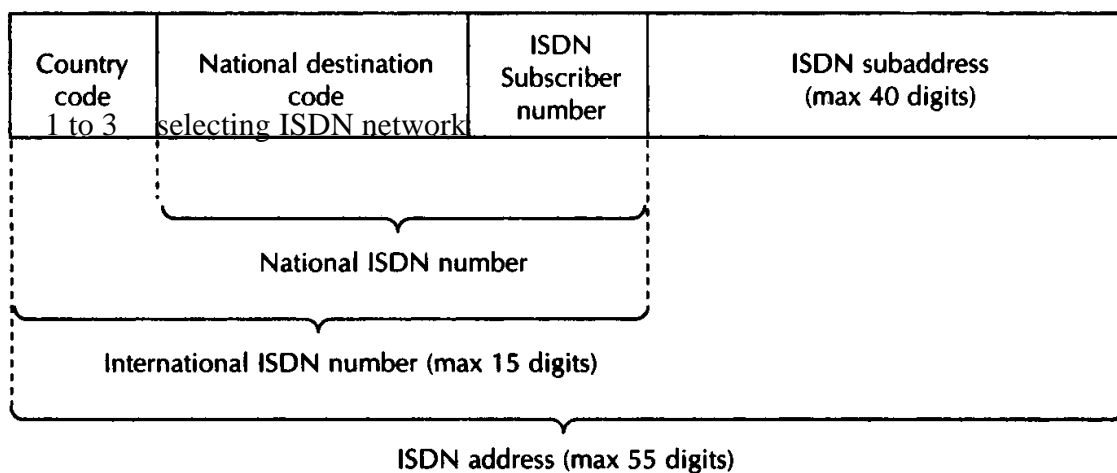

ISDN Address Structure

- ISDN number
contains sufficient information for network to route a call, corresponds to T reference point
- ISDN address
 - comprises of ISDN number and additional addressing information, corresponds to S reference point.
 - ISDN number is associated with a D channel, which provides CCS for a number of subscribers, each if which has an ISDN address.

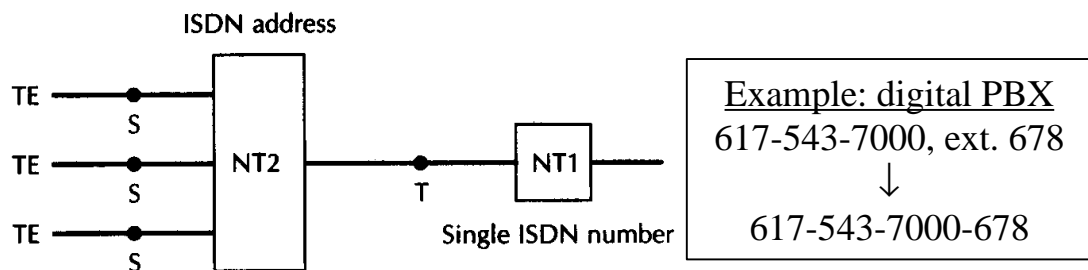

(a) Single ISDN number at T interface

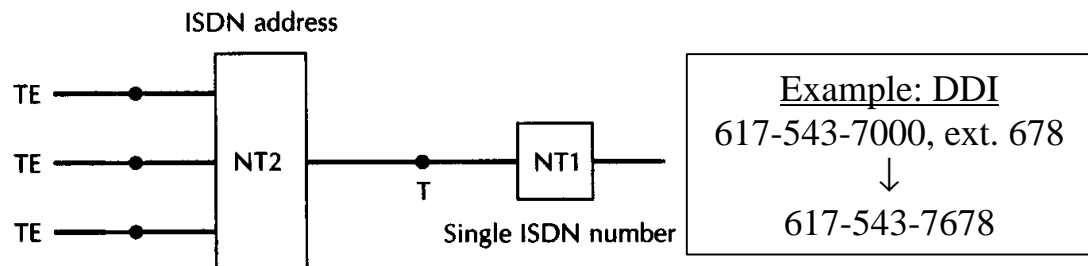

(b) Direct dialing-in

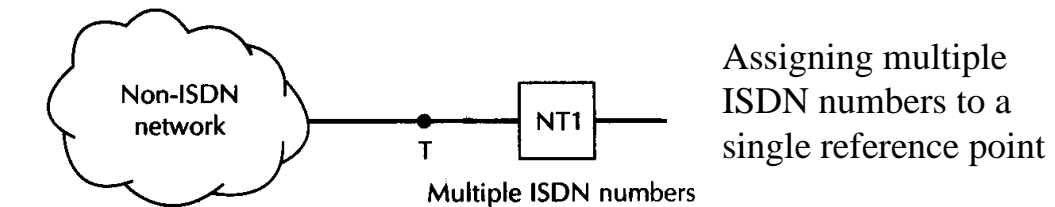

(c) Non-ISDN network

ISDN Addressing

Numbering interworking

- Incompatibility between different numbering standards
- *Interworking strategies:*
 - An ISDN subscriber can set up a call to subscribers or services terminated on other public networks.
 - Single-stage and two-stage selection approaches
- **Single-stage approach**
 - calling party designates the address of the called party in the call setup procedure, contains sufficient information for routing the call to a point the called network attaches and that network routes the call to the called party.

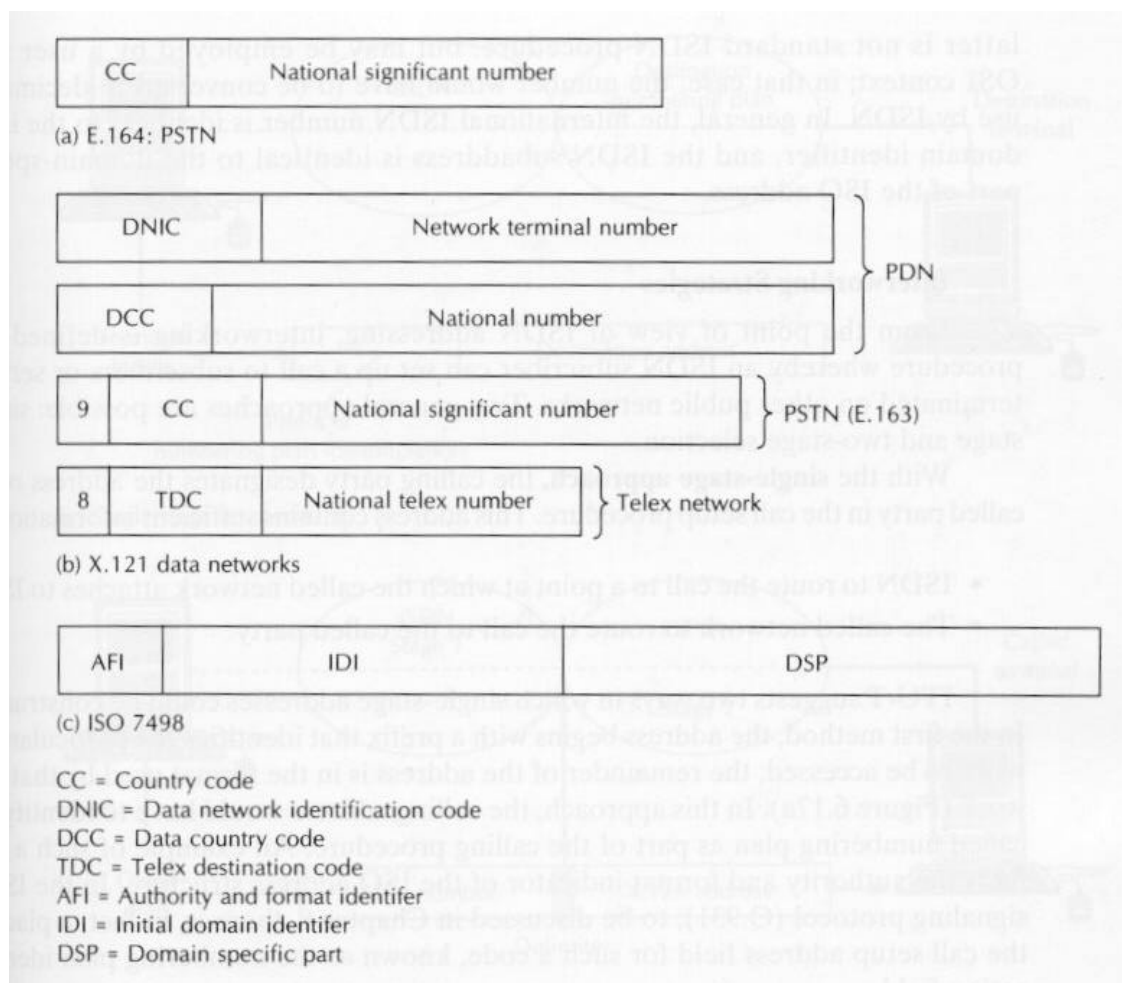

- **Two-stage approach**

- The first stage of selection provides the calling party access via ISDN to an interworking unit (IWU).
- The necessary address information is forwarded for the called party on that particular network.
- Disadvantages are:
 - additional digits must be dialed by the caller
 - the caller must employ two numbering plans
 - a delimiter or pause is necessary between two stages (a second dial tone)

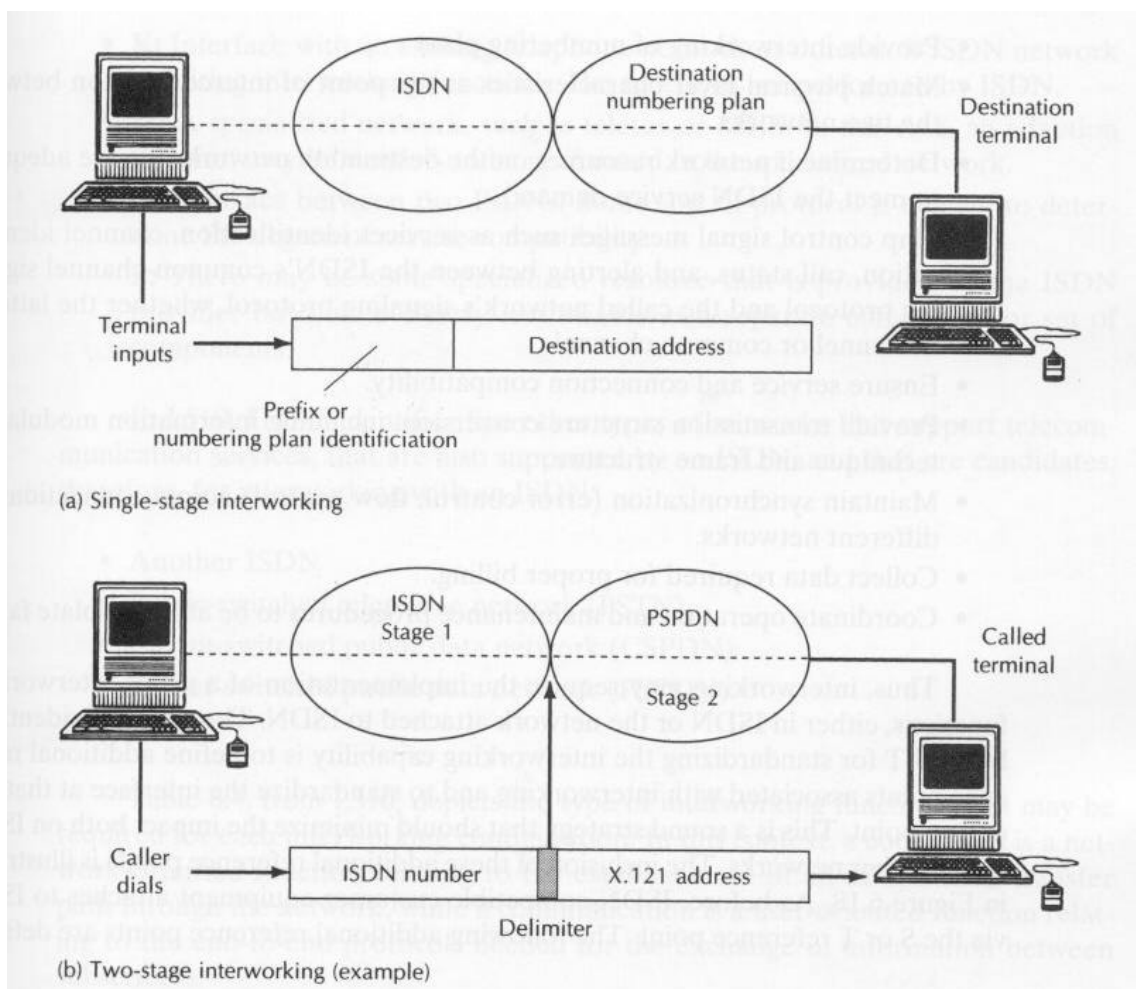

Numbering interworking strategies

3.6 Interworking

Interworking of ISDN with other non-ISDN and ISDN networks are essential

- **Typical functions for interworking between networks are:**
 - provide interworking of numbering plans
 - match physical-layer characteristics at the point of interconnection between the two networks
 - determine if network resources on the destination network side are adequate to meet the ISDN service demand
 - map control signal messages such as services identification, channel identification, call status, and alerting between the ISDN's CCS protocol and the called network's signaling protocol, whether the latter is inchannel or common channel
 - ensure service and connection compatibility
 - provide transmission structure conversion, including information modulation technique and frame structure
 - maintain synchronization (error and flow control) across connections on different networks
 - collect data required for proper billing
 - coordinate operation and maintenance procedures to be able to isolate faults
- Interworking may require the implementation of a set of interworking functions, either in ISDN or the attached network.
- ITU-T approach is to define additional reference points associated with interworking and to standardize the interface at that reference point.

Additional reference points for interworking

- An ISDN-compatible customer equipment attaches to ISDN via S or T reference point, for others, there are these additional:
 - **K**: Interface with an existing telephone network or other non-ISDN network requiring interworking functions. The functions are performed by ISDN.
 - **M**: A specialized network, such as teletex or MHS. In this case, an adaption function may be needed, to be performed in that network.
 - **N**: Interface between two ISDNs. Some sort of protocol is needed to determine the degree of service compatibility.
 - **P**: There may be some specialized resource that is provided by the ISDN provider but that is clearly identifiable as a separate component or set of components.
- Interworkable networks with ISDN defined in ITU-T I.510

Another ISDN, PSTN, CSPDN, PSPDN, Telex

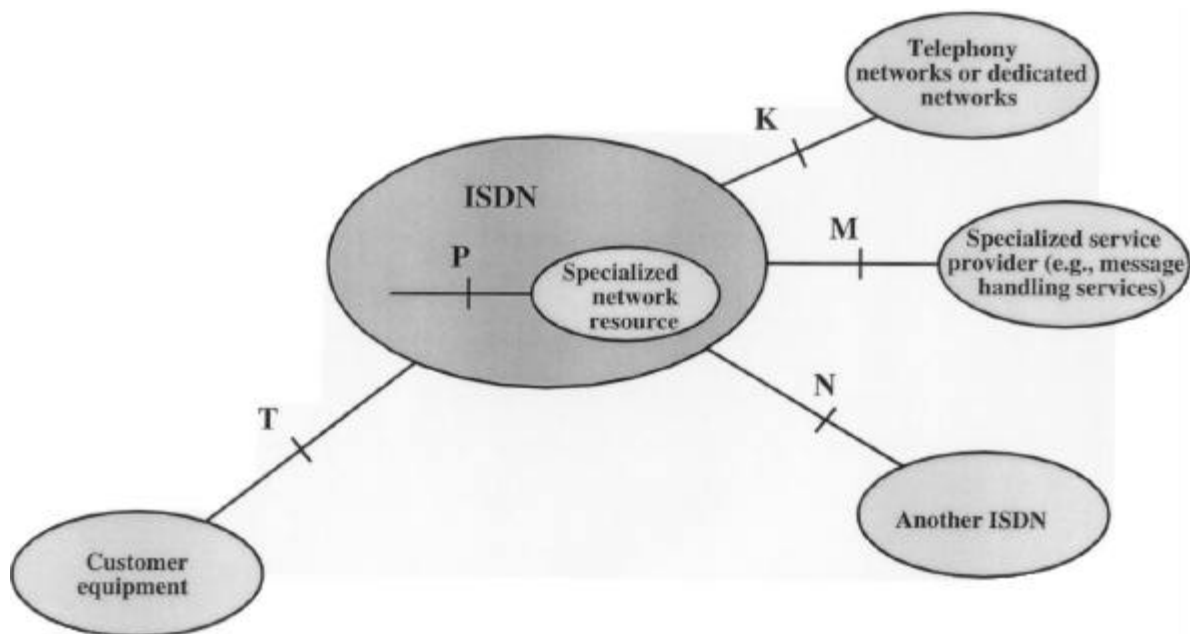

Reference points associated with the interconnection of customer equipment and other networks to an ISDN

ISDN Interconnected with						
Services Supported by ISDN	ISDN	PSTN	CSPDN	PSPDN	TELEX	Other Dedicated Network
Telephony	O	N	—	—	—	N
Data transmission	(L)	N, L	N, (L)	N, (L)	—	N, (L)
Telex	O	—	—	—	N, L	N, L
Teletex	O	N, L	N, L	N, L	—	N, L, H
Facsimile	O	N, L	N, L	N, L	—	N, L, H

O No interworking function foreseen

N Connection-dependent interworking needed

L Lower-layer communication-dependent interworking needed

H Higher-layer communication-dependent interworking needed

(X) X may be needed

ISDN support of telecom services in an interworking configuration (I.510)

	ISDN	PSTN	Interworking Functions
Subscriber interface	Digital	Analog	a
User-network signaling	Out of band (I.441/I.451)	Mainly inband (e.g., DTMF)	b, e
User terminal equipment supported	Digital TE (ISDN NT, Te1 or TE2 + TA)	Analog TE (e.g., dial pulse telephones, PBXs, modem-equipped DTEs)	c
Interexchange signaling	SS7 ISDN User Part (ISUP)	Inband (e.g., R1, R2, SS4, SS 5) or out of band (e.g., SS 6, SS7 TUP)	d, e
Transmission facilities	Digital	Analog/digital	a
Information transfer mode	Circuit/packet	Circuit	f
Information transfer capability	Speech, digital unrestricted, 3.1-kHz audio, video, etc.	3.1-kHz audio (voice/voiceband data)	f

a = Analog-to-digital and digital-to-analog conversion on transmission facilities.

b = Mapping between PSTN signals in the subscriber access and I.451 messages for intra-exchange calls.

c = Support of communication between modem-equipped PSTN DTEs and ISDN terminals.

d = Conversion between the PSTN signaling system and Signaling System No. 7 ISDN user part.

e = Mapping between signals in the ISDN subscriber (I.441, I.451) access and PSTN inband interexchange signaling (e.g., R1).

f = Further study required.

Key ISDN and PSTN characteristics

Call negotiation procedure in ISDN-ISDN interworking

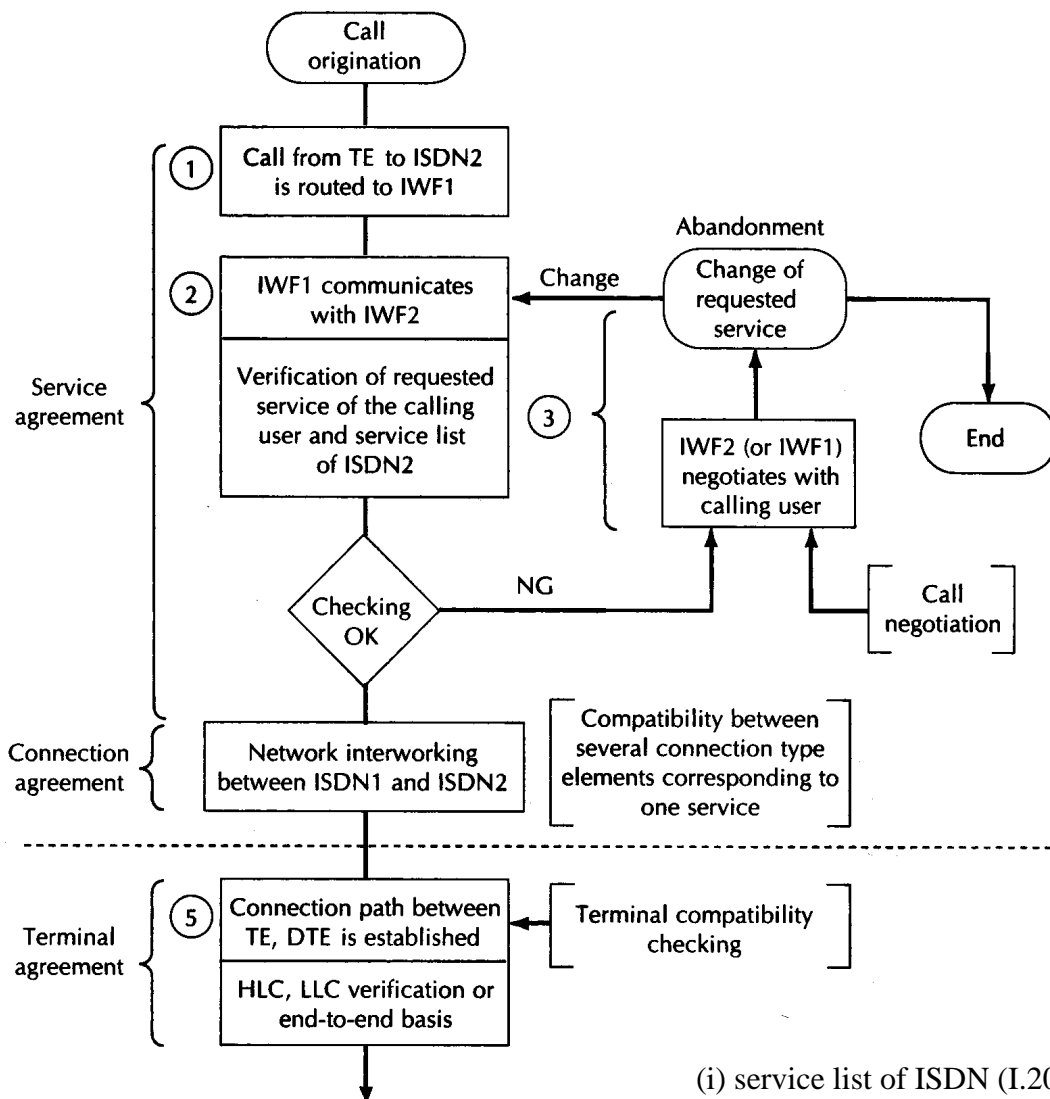
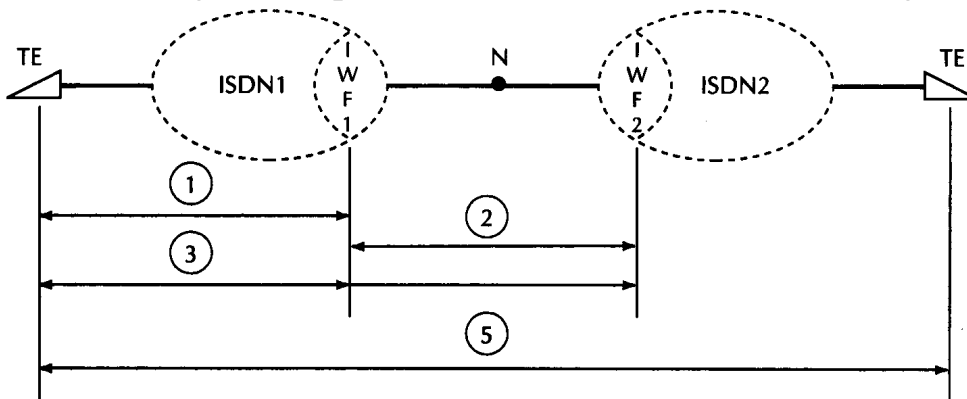

Function and information to be supported by IWF

- (i) service list of ISDN (I.200)
- (ii) service agreement
- (iii) network interworking